

Installation, Maintenance, and Repair Manual

Series 009, LF009, LFU009, SS009, U009

Reduced Pressure Zone Assemblies

1/4" – 3"

⚠ WARNING



Read this Manual **BEFORE** using this equipment. Failure to read and follow all safety and use information can result in death, serious personal injury, property damage, or damage to the equipment. Keep this Manual for future reference.



⚠ WARNING

Local building or plumbing codes may require modifications to the information provided. You are required to consult the local building and plumbing codes prior to installation. If this information is not consistent with local building or plumbing codes, the local codes should be followed.

⚠ WARNING

Need for Periodic Inspection/Maintenance: This product must be tested periodically in compliance with local codes, but at least once per year or more as service conditions warrant.

If installed on a fire suppression system, all mechanical checks, such as alarms and backflow preventers, should be flow tested and inspected in accordance with NFPA 13 and/or NFPA 25.

Corrosive water conditions and/or unauthorized adjustments or repair could render the product ineffective for the service intended. Regular checking and cleaning of the product's internal components helps assure maximum life and proper product function.

NOTICE

For Australia and New Zealand, line strainers should be installed between the upstream shutoff valve and the inlet of the backflow preventer.

Fittings such as end connectors intended to join alternative pipe systems made from other materials (such as plastics) shall also conform to the relevant dimensional and performance requirements of the appropriate Australian, New Zealand, or joint Australian–New Zealand Standard for the alternative pipe system.

Testing

For field testing procedure, refer to IS-TK-DL, IS-TK-9A, IS-TK-99E, and IS-TK-99D at watts.com.

For Australia, refer to Australian standard AS/NZS 2845.3.

For other repair kits and service parts, refer to the Backflow Prevention Products Repair Kits & Service Parts price list PL-RP-BPD at watts.com.

For technical assistance, contact your local Watts representative.



LF009 with Flood Sensor

Series 009 assemblies, sizes 1/2" to 3", include a sensor on the relief valve to detect excessive discharge and trigger notification of a potential flood event.

NOTICE

An add-on connection kit is required to activate the flood sensor. Without the connection kit, the flood sensor is a passive component that has no communication with any other device. (A retrofit sensor connection kit is also available for existing installations. See "Add-on and Retrofit Sensor Connection Kits," for ordering details.)

NOTICE

Use of the flood sensor does not replace the need to comply with all required instructions, codes, and regulations related to installation, operation, and maintenance of this product, including the need to provide proper drainage in the event of a discharge.

Watts no es responsable de la falla de las alertas debido a problemas de conectividad, cortes de energía o instalación incorrecta.

Installation Guidelines

Indoors

For indoor installations, the assembly needs to be easily accessible to facilitate testing and servicing. If it is located in a line close to a wall, be sure the test cocks are easily accessible. A drain line and air gap should be piped from the relief valve connection as shown in Figure 1. This is where evidence of discharge is clearly visible, signaling the need to protect against water damage. Therefore, never install the assembly in concealed locations. (For more information, download the ES-AG/EL/TC specification at watts.com.)

Outside

In an area where freezing conditions do not occur, the assembly can be installed outside. The most satisfactory installation is above ground; thus, the assembly should be installed in this manner.

Backflow preventers should not be installed in pits unless approved by local codes. In such cases, a modified pit installation is preferred.

NOTICE

In an area where freezing conditions can occur, the assembly should be installed above ground in an insulated enclosure, as shown in Figure 2. (For more information, download the ES-WB specification at watts.com.)

The assembly must be installed in an accessible location to facilitate testing and servicing. A discharge line should be piped from the air gap at the relief valve connection to ensure there is adequate drainage. Never pipe the discharge line directly into a drainage ditch, sewer, or sump. Never install the assembly where any part of the unit could become submerged in standing water.

Parallel

Two or more smaller-sized assemblies can be piped in parallel (when approved) to serve a large supply pipe main, as shown in Figure 3. This type of installation is employed where increased capacity is needed beyond that provided by a single valve and permits testing or servicing of an individual valve without shutting down the complete line.

The number of assemblies used in parallel should be determined by the engineer's judgment based on the operating conditions of a specific installation.

For parallel valve installations, the total capacity of the assemblies should equal or exceed that required by the system.

Figure 1

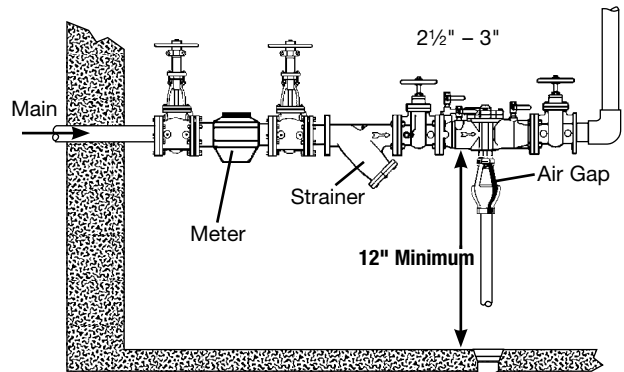

Figure 2

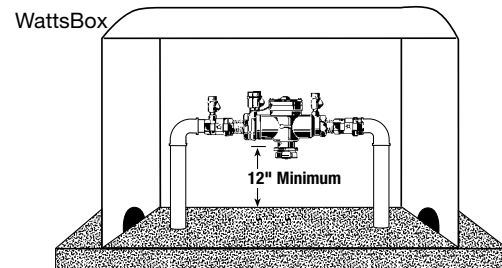
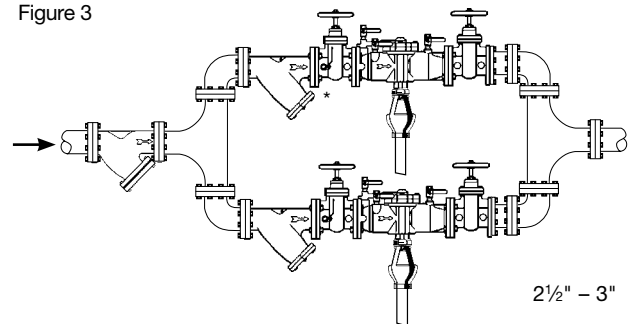

Figure 3



Annual Inspection

Annual inspection of all water system safety and control valves is required and necessary. Regular inspection, testing, and cleaning assures maximum life and proper product function.

NOTICE

Shutoff Valves: When shutoff valves are removed and reassembly is necessary, the shutoff valve with the test cock is to be mounted on the inlet side of the backflow preventer.

- A. The assembly should always be installed in an accessible location to facilitate testing and servicing. **Check the state and local codes to ensure that the backflow preventer is installed in compliance, such as the proper height above the ground.**
- B. Watts recommends that a strainer be installed ahead of the assembly to protect the internal components from unnecessary fouling.

CAUTION

Do not add a strainer when the backflow preventer is installed on seldom-used water lines, such as fire sprinkler lines or other lines called upon only during emergencies.

Start Up: The downstream shutoff should be closed. Open the upstream shutoff slowly and fill the valve. When the valve is filled, open the downstream shutoff slowly and fill the water supply system. This is necessary to avoid water hammer or shock damage.

- C. Water discharge from the relief valve should be vented in accordance with code requirements. The relief valve should never be solidly piped into a drainage ditch, sewer, or sump. The discharge should be terminated approximately 12" above the ground or through an air gap piped to a floor drain.

NOTICE

Relief Valve Discharge Rates

The installation of an air gap with the drain line terminating above a floor drain handles any normal discharge or nuisance spitting through the relief valve. However, floor drain size may need to be designed to prevent water damage caused by a catastrophic failure condition. See Figure 4 for maximum relief valve discharge rates, size, and capacity of typical floor drains.

Do not reduce the size of the drain line from the air gap fitting. Pipe full line size.

- D. After initial installation, a discharge from the relief valve opening may occur due to inadequate initial flushing of pipe lines to eliminate dirt and pipe compounds. If flushing does not clear, remove the first check valve and clean thoroughly.

NOTICE

Periodic relief valve discharge may occur on dead end service applications, such as boiler feed lines or cooling tower makeup lines due to fluctuating supply pressure during a static or no flow condition. To avoid this discharge, install a spring-loaded rubber seated check valve ahead of the backflow assembly to "lock-in" the downstream pressure.

- E. Backflow preventers should never be placed in pits unless absolutely necessary and then only when and as approved by local codes. In such cases, provision should be made to always vent above flood level or for a pit drain to ensure an adequate air gap below the relief port.

- F. The backflow preventers must be inspected periodically for any discharge from the relief valve which provides a visual indication of need for cleaning or repair of check valves. Also testing for proper operation of the device should be made periodically in compliance with local codes, but at least once a year or more often, depending upon system conditions.

The relief vent discharges water when, during no-flow periods, the first check valve is fouled or the inlet pressure to the device drops sufficiently due to upstream pressure fluctuations to affect the required operating differential between the inlet pressure and reduced pressure zone. Otherwise, such relief (spitting) can occur when the second check is fouled during emergency backflow or resulting from a water hammer condition. (For more information, download Troubleshooting Guide S-TSG at watts.com.)

NOTICE

Special considerations are necessary when testing assemblies installed on Fire Prevention Systems.

Fire Protection System Installations: The National Fire Protection Agency (NFPA) Guidelines require a confirming flow test be conducted whenever a "main line" valve such as a backflow assembly or the shutoff valves have been operated. Certified testers of backflow assemblies must conduct this confirming test.

Figure 4

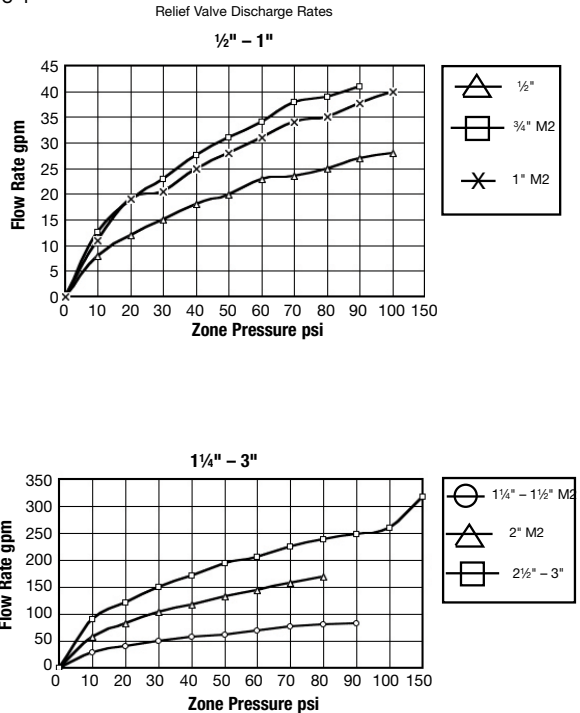

TYPICAL FLOW RATES AS SIZED BY FLOOR DRAIN MANUFACTURERS	
2" 55 gpm	5" 350 gpm
3" 112 gpm	6" 450 gpm
4" 170 gpm	8" 760 gpm

Servicing the Relief Valve

NOTICE

No special tools are required to service assembly sizes 2½" to 3".

1. Detach the activation module, if installed, from the flood sensor then remove the sensor from the relief valve.
2. Remove the four or six relief valve cover bolts while holding the cover down.
3. Lift the cover straight off. The stem and diaphragm assembly normally remain with the cover as it is removed. The relief valve spring is free inside the body at this point.
4. The relief valve seat is located at the bottom of the body bore, and can be removed, if necessary, for cleaning. The disc can be cleaned without disassembly of the relief valve module. If it is determined that the relief valve diaphragm and/or disc should be replaced, the relief valve module can be readily disassembled without the use of special tools.

NOTICE

The disc rubber is molded into the disc holder and is supplied as a disc holder assembly.

5. To reassemble the relief valve, press the seat firmly into place in the body, center the spring on the seat, and insert the cover and relief valve module as a unit straight into the bore. Press down on the cover to assure proper alignment. Insert and tighten bolts.
6. Reattach the flood sensor to the relief valve and mount the activation module to the sensor.

NOTICE

If the cover does not press flat against the body, the stem assembly is crooked and damage can result. Realign the stem and cover before bolts are inserted.

2½" - 3"

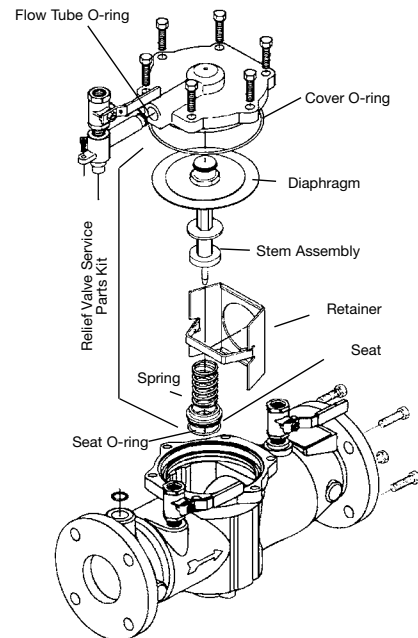
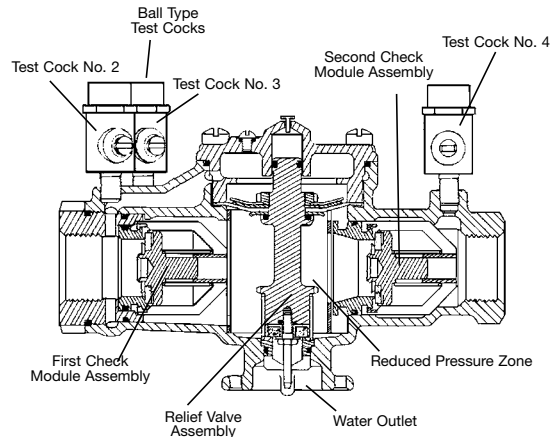

1" - 2"

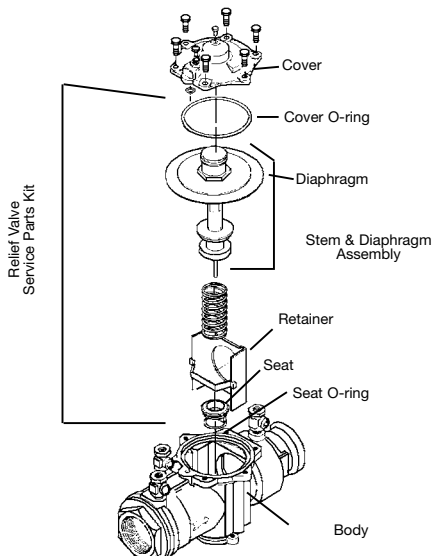
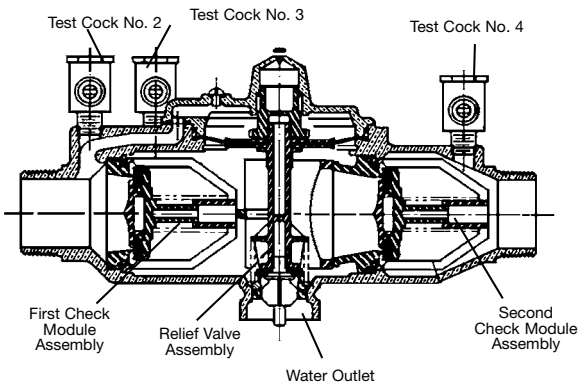

Servicing First and Second Check Valves

1. Remove the relief valve assembly by following the preceding procedure.
2. Remove the retainer from the body bore. The check valve modules can now be removed from the valve by hand or with a screwdriver.

NOTICE

The seats and springs of the first and second check modules are not interchangeable. The heavier spring and smaller diameter seat belong with the first check module.

3. The check seats are attached to the cage with a bayonet type locking arrangement. Holding the cage in one hand, push the seat inward and rotate counterclockwise for 2½" to 3"; clockwise for ¼" to 2" against the cage. The seat, spring cage, spring, and disc assembly are now individual components.
4. The disc assembly may now be cleaned and reassembled or, depending on its condition, discarded and replaced with a new assembly from the repair kit. O-rings should be cleaned or replaced as necessary and lightly greased with the FDA-approved silicon grease.
5. Reassemble the check valve modules. Check modules are installed in the valve body with the seat facing the valve inlet. The modules must be securely in place before the retainer can be replaced. Reinstall relief valve assembly as well as flood sensor and activation module.

NOTICE

No special tools are required to service assembly sizes 2½" to 3".

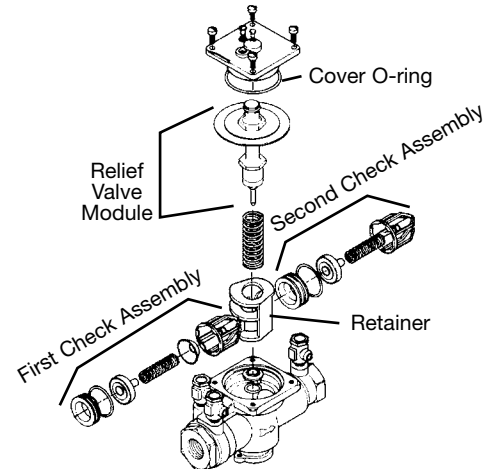
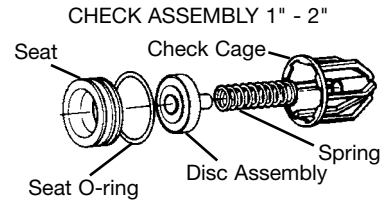

CHECK ASSEMBLY ¼" M3

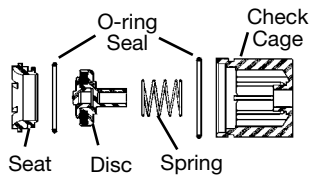

CHECK ASSEMBLY ¼" - ¾"

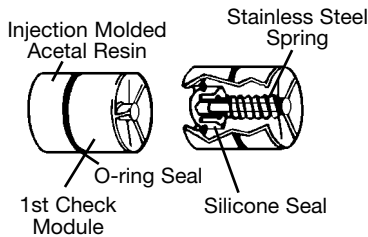



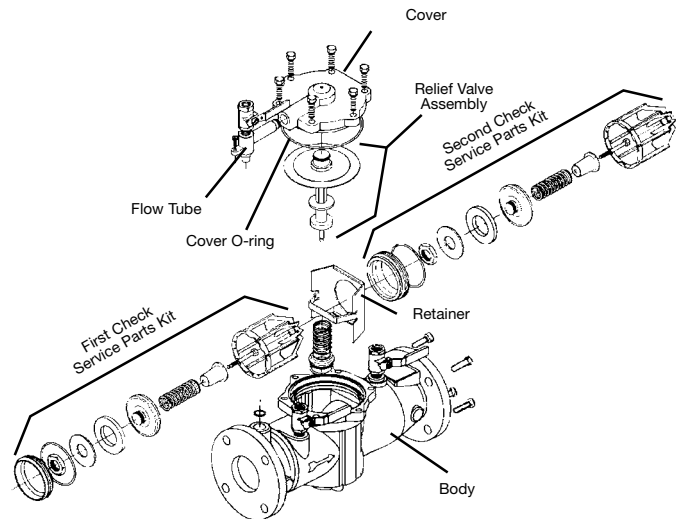
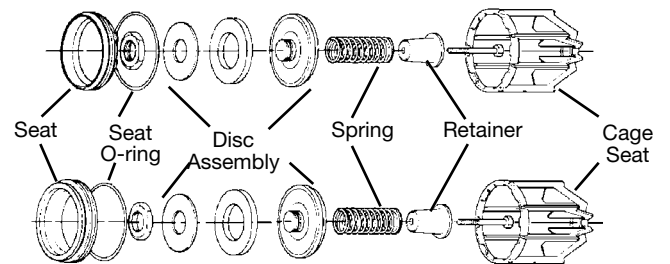

CHECK ASSEMBLY 2½" - 3"







Troubleshooting

SYMPTOM	CAUSE	SOLUTION
Check valve fails to hold 1.0 PSID minimum	Debris on check disc sealing surface	Disassemble and clean
	Leaking isolation valve	Disassemble and clean or repair
	Damaged seat disc or seat O-ring	Disassemble and replace
	Damaged guide holding check open	Disassemble and clean or replace
	Weak or broken spring	Disassemble and replace spring
Chatter during flow conditions	Worn, damaged or defective guide	Disassemble and repair or replace guide
Low flows passing through mainline valve	Mainline check fouled	Disassemble and clean
	Meter strainer plugged	
	Damaged mainline seat disc or seat	Disassemble and replace
	Broken mainline spring	

Add-on and Retrofit Sensor Connection Kits for Building Management Systems

ORDERING CODE	ADD-ON/RETROFIT KIT	DESCRIPTION
88003056	 <p>FP-BF-BMS BMS Sensor Connection Kit Series 009, LF009, LFU009, SS009, U009 Sizes ½" to 3"</p>	Includes sensor activation module with cable, deflector (4), ground wire, and power adapter. Use this kit to activate the flood sensor and enable flood detection capabilities on the relief valve of a new installation working with a BMS controller (not included).
88003057	 <p>FP-RFK-BF-BMS-CFS BMS Sensor Retrofit Connection Kit Series 009, LF009, LFU009, SS009, U009 Sizes ½" to ¾"</p>	Includes flood sensor, deflector, sensor activation module with cable, ground wire, and power adapter. Use this kit to install the flood sensor and enable flood detection capabilities on the relief valve of an existing installation working with a BMS controller (not included).
88003058	 <p>FP-RFK-BF-BMS-CFS BMS Sensor Retrofit Connection Kit Series 009, LF009, LFU009, SS009, U009 Sizes 1" to 1½"</p>	Includes flood sensor, deflector (2), sensor activation module with cable, mounting bolts, ground wire, and power adapter. Use this kit to install the flood sensor and enable flood detection capabilities on the relief valve of an existing installation working with a BMS controller (not included).
88003059	 <p>FP-RFK-BF-BMS-CFS BMS Sensor Retrofit Connection Kit Series 009, LF009, LFU009, U009 Sizes 2" to 3"</p>	Includes flood sensor, deflector, sensor activation module with cable, mounting bolts, ground wire, and power adapter. Use this kit to install the flood sensor and enable flood detection capabilities on the relief valve of an existing installation working with a BMS controller (not included).

Add-on and Retrofit Sensor Connection Kits for Cellular Communication

ORDERING CODE	ADD-ON/RETROFIT KIT	DESCRIPTION
88003060	 <p>FP-BF-CFS Cellular Sensor Connection Kit Series 009, LF009, LFU009, SS009, U009 Sizes ½" to 3"</p>	Includes sensor activation module with cable, deflector (4), Cellular Gateway with mounting kit, ground wire, and power adapter. Use this kit to activate the flood sensor and enable flood detection capabilities on the relief valve of a new installation working with cellular communication to send alerts by email message, SMS text message, or voice call.
88003061	 <p>FP-RFK-BF-CFS Cellular Sensor Retrofit Connection Kit Series 009, LF009, LFU009, SS009, U009 Sizes ½" to ¾"</p>	Includes flood sensor, deflector, sensor activation module with cable, Cellular Gateway with mounting kit, ground wire, and power adapter. Use this kit to install the flood sensor and enable flood detection capabilities on the relief valve of an existing installation working with cellular communication to send alerts by email message, SMS text message, or voice call.
88003062	 <p>FP-RFK-BF-CFS Cellular Sensor Retrofit Connection Kit Series 009, LF009, LFU009, SS009, U009 Sizes 1" to 1½"</p>	Includes flood sensor, deflector (2), sensor activation module with cable, mounting bolts, Cellular Gateway with mounting kit, ground wire, and power adapter. Use this kit to install the flood sensor and enable flood detection capabilities on the relief valve of an existing installation working with cellular communication to send alerts by email message, SMS text message, or voice call.
88003063	 <p>FP-RFK-BF-CFS Cellular Sensor Retrofit Connection Kit Series 009, LF009, LFU009, U009 Sizes 2" to 3"</p>	Includes flood sensor, deflector, sensor activation module with cable, mounting bolts, Cellular Gateway with mounting kit, ground wire, and power adapter. Use this kit to install the flood sensor and enable flood detection capabilities on the relief valve of an existing installation working with cellular communication to send alerts by email message, SMS text message, or voice call.

Limited Warranty: Watts (the "Company") warrants each product to be free from defects in material and workmanship under normal usage for a period of one year from the date of original shipment. In the event of such defects within the warranty period, the Company will, at its option, replace or recondition the product without charge.

THE WARRANTY SET FORTH HEREIN IS GIVEN EXPRESSLY AND IS THE ONLY WARRANTY GIVEN BY THE COMPANY WITH RESPECT TO THE PRODUCT. THE COMPANY MAKES NO OTHER WARRANTIES, EXPRESS OR IMPLIED. THE COMPANY HEREBY SPECIFICALLY DISCLAIMS ALL OTHER WARRANTIES, EXPRESS OR IMPLIED, INCLUDING BUT NOT LIMITED TO THE IMPLIED WARRANTIES OF MERCHANTABILITY AND FITNESS FOR A PARTICULAR PURPOSE.

The remedy described in the first paragraph of this warranty shall constitute the sole and exclusive remedy for breach of warranty, and the Company shall not be responsible for any incidental, special or consequential damages, including without limitation, lost profits or the cost of repairing or replacing other property which is damaged if this product does not work properly, other costs resulting from labor charges, delays, vandalism, negligence, fouling caused by foreign material, damage from adverse water conditions, chemical, or any other circumstances over which the Company has no control. This warranty shall be invalidated by any abuse, misuse, misapplication, improper installation or improper maintenance or alteration of the product.

Some States do not allow limitations on how long an implied warranty lasts, and some States do not allow the exclusion or limitation of incidental or consequential damages. Therefore the above limitations may not apply to you. This Limited Warranty gives you specific legal rights, and you may have other rights that vary from State to State. You should consult applicable state laws to determine your rights. **SO FAR AS IS CONSISTENT WITH APPLICABLE STATE LAW, ANY IMPLIED WARRANTIES THAT MAY NOT BE DISCLAIMED, INCLUDING THE IMPLIED WARRANTIES OF MERCHANTABILITY AND FITNESS FOR A PARTICULAR PURPOSE, ARE LIMITED IN DURATION TO ONE YEAR FROM THE DATE OF ORIGINAL SHIPMENT.**



USA: T: (978) 689-6066 • Watts.com

Canada: T: (888) 208-8927 • Watts.ca

Latin America: T: (52) 55-4122-0138 • Watts.com

