

Installation, Maintenance, and Repair Manual

Series 007, LF007

Double Check Valve Assemblies

1/2" - 2"

⚠ WARNING



Read this Manual **BEFORE** using this equipment. Failure to read and follow all safety and use information can result in death, serious personal injury, property damage, or damage to the equipment. Keep this Manual for future reference.



⚠ WARNING

Local building or plumbing codes may require modifications to the information provided. You are required to consult the local building and plumbing codes prior to installation. If the information provided here is not consistent with local building or plumbing codes, the local codes should be followed. This product must be installed by a licensed contractor in accordance with local codes and ordinances.

⚠ WARNING

Need for Periodic Inspection/Maintenance: This product must be tested periodically in compliance with local codes, but at least once per year or more as service conditions warrant. All products must be retested once maintenance has been performed. Corrosive water conditions and/or unauthorized adjustments or repair could render the product ineffective for the service intended. Regular checking and cleaning of the product's internal and external components helps assure maximum life and proper product function.

⚠ WARNING

Freeze sensor solely provides alerts about a possible freeze event and cannot prevent a freeze event from occurring. User action is required to prevent freeze conditions from causing product and/or property damage.

NOTICE

For Australia and New Zealand, line strainers should be installed between the upstream shutoff valve and the inlet of the backflow preventer.

Fittings such as end connectors intended to join alternative pipe systems made from other materials (such as plastics) shall also conform to the relevant dimensional and performance requirements of the appropriate Australian, New Zealand, or joint Australian–New Zealand Standard for the alternative pipe system.

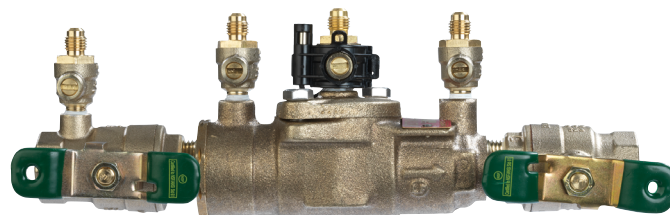

LF007 with Freeze Sensor

Series 007 and LF007 small-diameter backflow preventers are designed for installation at referenced cross-connections to prevent the backflow of polluted water into the potable water supply. Both series include a freeze sensor to signal building/irrigation management systems when temperature hits the freeze thresholds.

NOTICE

An add-on connection kit is required to activate the freeze sensor. Without the connection kit, the sensor is a passive component that does not communicate with any other device. (The kit can also be used to retrofit existing installations. For ordering details, see "Add-on Sensor Connection Kit.") BMS/IMS only.

NOTICE

Use of freeze sensor does not remove the need to comply with all required instructions, codes, and regulations related to installation, operation, and maintenance of the backflow preventer.

Watts is not responsible for data transmission failures or the failure of alerts due to connectivity issues, power outages, or improper installation.

Testing

For field testing procedure, refer to the Watts installation sheets IS-TK-DL, IS-TK-9A, IS-TK-99E and IS-TK-99D at www.watts.com.

For Australia, refer to Australian standard AS/NZS 2845.3.

For technical assistance, contact your local Watts representative.

Installation Guidelines

Indoors

Check local codes for installation requirements. Pipelines should be thoroughly flushed to remove foreign material before installing the unit. A strainer should be installed ahead of the backflow preventer to prevent the disc from unnecessary fouling, whether in horizontal or vertical position. (See Figure 1.) Install the valve inline with the arrow on valve body pointing in the direction of flow.

For indoor installations, the valve must be easily accessible to facilitate testing and servicing. The assembly can also be installed in a WattsBox insulated enclosure. (See Figure 2.) Do not install the assembly in a concealed location.

CAUTION

Do not install a strainer when the backflow preventer is intended for seldom-used water lines that are activated during emergencies, such as fire sprinkler lines.

Series 007 and LF007 must be tested periodically in compliance with local codes, but at least once a year or more often depending upon system conditions. Regular inspection, testing, and cleaning assure maximum life and proper product function.

NOTICE

Fire Protection System Installations. The National Fire Protection Agency (NFPA) Guidelines require a confirming flow test to be conducted whenever a "main line" valve such as a backflow assembly or the shutoff valves have been operated. Certified testers of backflow assemblies must conduct this test. The trim valves of the detector meter bypass line, on assemblies so equipped, should be shutoff during the confirming flow test. When the test is completed, the trim valves must be returned to a fully open position.

Figure 1

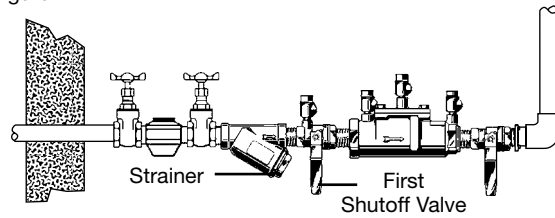

007QT-S / LF007QT-S

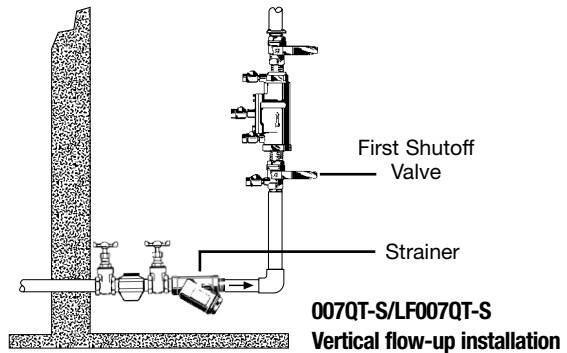

Meter Box Installation

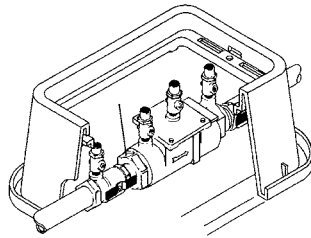
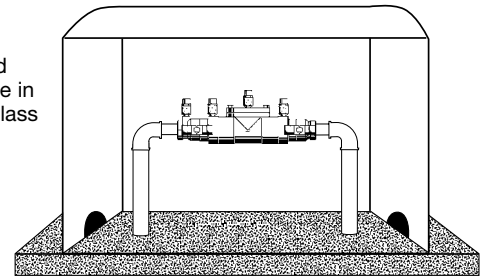

Figure 2

WattsBox Insulated Enclosure, available in aluminum or fiberglass



Parallel

Two or more Series 007 and LF007 smaller size valves may be piped in parallel (where approved) to serve a larger supply pipe main. (See Figure 3.) This type of installation is employed whenever it is vital to maintain a continuous supply of water or where interruptions for testing and servicing would be unacceptable. The installation increases capacity where needed beyond that provided by a single valve and permits testing or servicing of an individual valve without shutting down the complete line.

For two valve installations the total capacity of the devices should equal or exceed that required by the system.

The quantity of valves used in parallel should be determined by the judgment of the compliance engineer, based on the operating conditions of a specific installation.

Figure 3

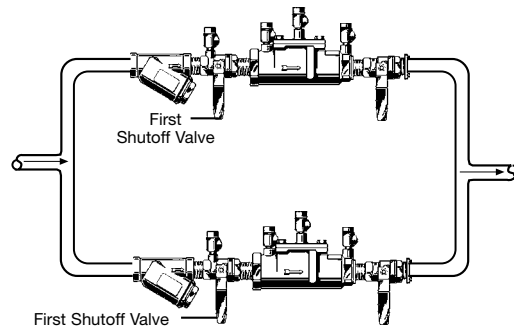

007QT-S / LF007QT-S

Servicing the Check Valves

NOTICE

Before servicing, ensure the supply water is turned off or the shutoff valves are in the closed position. **Open test cocks No. 2, No. 3, and No. 4 to relieve pressure inside the before removing the valve cover.**

1. Remove the cover, then remove the retainer from the body valve. The check valve modules can be removed from the valve by hand or with a screwdriver.

NOTICE

For Series 007 and LF007, sizes 1/2" - 2", the seats and springs of the first and second check modules are not interchangeable. The heavier spring and smaller diameter seat belong with the first check module. Series 007M1 sizes 3/4" to 1" and Series 007M2 size 3/4" have interchangeable seats and springs.

2. The check seats are attached to the cage with a bayonet type locking arrangement. Holding the cage in one hand, push the seat inward and rotate clockwise against the cage. Series 007M2/LF007M2 size 3/4" and LF007 have a pull-apart seat and cage. The seat, cage, and spring and disc assembly are individual components.
3. Clean and reassemble the disc assembly or, depending on its condition, discard and replace it with a new assembly from the repair kit. O-rings should be cleaned or replaced as necessary.
4. Reassemble the check valve module in the reverse order. Check modules are installed in the valve body with the seats facing the valve inlet. The modules must be securely in place before the retainer is replaced. On sizes 3/4" to 1" this retainer may have to be tilted slightly into place. **Replace the cover, and close all test cocks before returning the valve to service.**

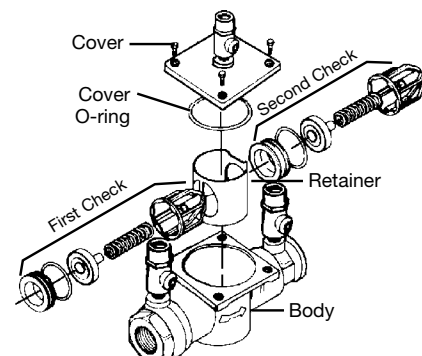
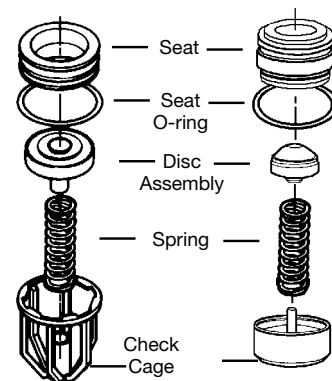
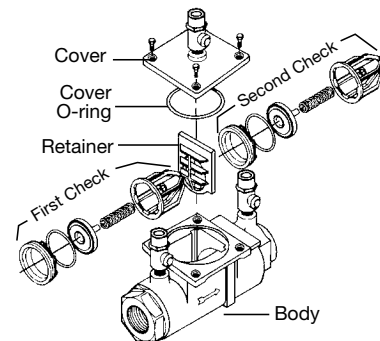
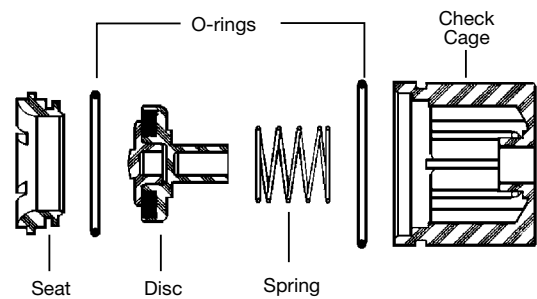

Troubleshooting

Call customer service if you need assistance with technical details.

SYMPTOM	CAUSE	SOLUTION
Check valve fails to hold 1.0 PSID minimum	Debris on check disc sealing surface	Disassemble and clean
	Leaking gate valve	Disassemble and clean or repair
	Damaged seat disc or seat O-ring	Disassemble and replace
	Damaged guide holding check open	Disassemble and clean or replace
	Weak or broken spring	Disassemble and replace spring
Chatter during flow conditions	Worn, damaged or defective guide	Disassemble and repair or replace guide
Low flows passing through mainline valve	Mainline check fouled	Disassemble and clean
	Meter strainer plugged	Disassemble and clean
	Damaged mainline seat disc or seat	Disassemble and replace
	Broken mainline spring	Disassemble and replace

Add-on Monitoring Connection Kits

ORDERING CODE	ADD-ON/RETROFIT KIT	DESCRIPTION
88009429	 FP-BF-BMS/IMS-FZ BMS/IMS Freeze Sensor Connection Kit	Includes freeze sensor in mounting clip, activation module with mounting hardware, wire nuts (2), and power adapter. Use this kit to add an indicator of the freeze threshold for PVB assemblies in a BMS/IMS configuration.

Limited Warranty: Watts Regulator Co. (the "Company") warrants each product to be free from defects in material and workmanship under normal usage for a period of one year from the date of original shipment. In the event of such defects within the warranty period, the Company will, at its option, replace or recondition the product without charge.

THE WARRANTY SET FORTH HEREIN IS GIVEN EXPRESSLY AND IS THE ONLY WARRANTY GIVEN BY THE COMPANY WITH RESPECT TO THE PRODUCT. THE COMPANY MAKES NO OTHER WARRANTIES, EXPRESS OR IMPLIED. THE COMPANY HEREBY SPECIFICALLY DISCLAIMS ALL OTHER WARRANTIES, EXPRESS OR IMPLIED, INCLUDING BUT NOT LIMITED TO THE IMPLIED WARRANTIES OF MERCHANTABILITY AND FITNESS FOR A PARTICULAR PURPOSE.

The remedy described in the first paragraph of this warranty shall constitute the sole and exclusive remedy for breach of warranty, and the Company shall not be responsible for any incidental, special or consequential damages, including without limitation, lost profits or the cost of repairing or replacing other property which is damaged if this product does not work properly, other costs resulting from labor charges, delays, vandalism, negligence, fouling caused by foreign material, damage from adverse water conditions, chemical, or any other circumstances over which the Company has no control. This warranty shall be invalidated by any abuse, misuse, misapplication, improper installation or improper maintenance or alteration of the product.

Some States do not allow limitations on how long an implied warranty lasts, and some States do not allow the exclusion or limitation of incidental or consequential damages. Therefore the above limitations may not apply to you. This Limited Warranty gives you specific legal rights, and you may have other rights that vary from State to State. You should consult applicable state laws to determine your rights. **SO FAR AS IS CONSISTENT WITH APPLICABLE STATE LAW, ANY IMPLIED WARRANTIES THAT MAY NOT BE DISCLAIMED, INCLUDING THE IMPLIED WARRANTIES OF MERCHANTABILITY AND FITNESS FOR A PARTICULAR PURPOSE, ARE LIMITED IN DURATION TO ONE YEAR FROM THE DATE OF ORIGINAL SHIPMENT.**



USA: T: (978) 689-6066 • Watts.com

Canada: T: (888) 208-8927 • Watts.ca

Latin America: T: (52) 55-4122-0138 • Watts.com

