

Installation, Maintenance, and Repair Manual

Series 757, 757DCDA, LF757DCDA

Double Check Valve Assemblies Double Check Detector Assemblies

2½" – 10"

⚠ WARNING



Read this Manual **BEFORE** using this equipment.
Failure to read and follow all safety and use information can result in death, serious personal injury, property damage, or damage to the equipment.
Keep this Manual for future reference.



⚠ WARNING

You are required to consult the local building and plumbing codes prior to installation. If the information in this manual is not consistent with local building or plumbing codes, the local codes should be followed. Inquire with governing authorities for additional local requirements.

⚠ WARNING

Need for Periodic Inspection/Maintenance: This product must be tested periodically in compliance with local codes, but at least once per year or more as service conditions warrant. If installed on a fire suppression system, all mechanical checks, such as alarms and backflow preventers, should be flow tested and inspected in accordance with NFPA 13 and/or NFPA 25. All products must be retested once maintenance has been performed. Corrosive water conditions, and/or unauthorized adjustments or repair could render the product ineffective for the service intended. Regular checking and cleaning of the product's internal components helps assure maximum life and proper product function.

⚠ WARNING

Do not impede or prevent sleeve movement by installing riser cradle clamps or other obstructive elements on or around the sleeve. Sleeve movement is required to service the backflow.

NOTICE

For *Australia* and *New Zealand*, line strainers should be installed between the upstream shutoff valve and the inlet of the backflow preventer.

Fittings such as end connectors intended to join alternative pipe systems made from other materials (such as plastics) shall also conform to the relevant dimensional and performance requirements of the appropriate Australian, New Zealand, or joint Australian–New Zealand Standard for the alternative pipe system.

Testing

For field testing procedure, refer to IS-TK-DL, IS-TK-9A, IS-TK-99E, and IS-TK-99D at watts.com.

For Australia, refer to Australian standard AS/NZS 2845.3.

For technical assistance, contact your local Watts® representative.

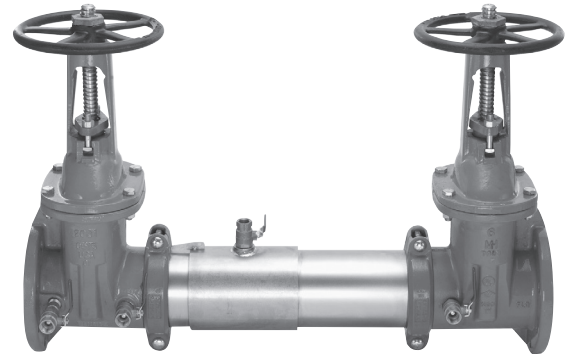

757 OSY

Installation Guidelines

Most field problems occur because dirt and debris present in the system at the time of installation become trapped in check No. 1. Flush the system before the backflow valve is installed. If the system is not flushed until after the backflow valve is installed, remove both check modules from the valve and open the inlet shutoff to allow water to flow for a sufficient time to flush debris from the water line. If debris in the water system continues to cause fouling, a strainer can be installed upstream of the backflow assembly.

Series 757 and 757DCDA/LF757DCDA can be installed in either horizontal or vertical position as long as the backflow assembly is installed in accordance with the direction of the flow arrow on the assembly and the local water authority approves the installation. (See illustrations of horizontal and vertical installations on p. 2.) The assembly should be installed with adequate clearance around the valve to allow for inspection, testing and servicing. Ensure a minimum clearance of 12" between the lower portion of the assembly and the floor or grade.

NOTICE

Assembly body should not be painted.

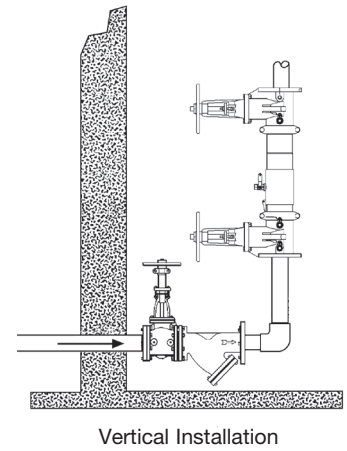
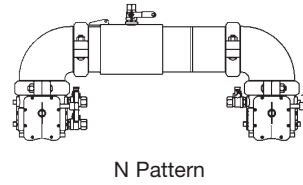
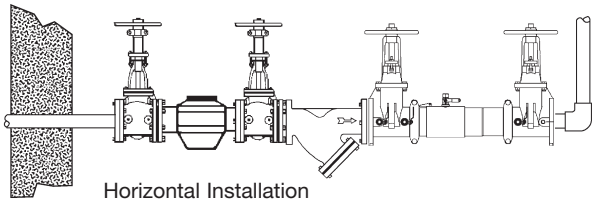

Maintaining the Check Modules

2 1/2" – 6"

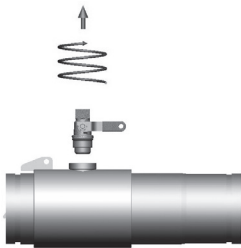

Figure A

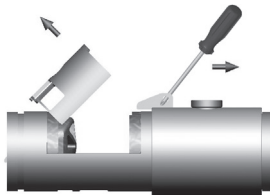

Figure B

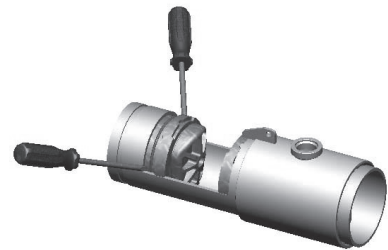

Figure C

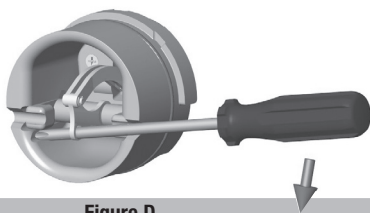

Figure D

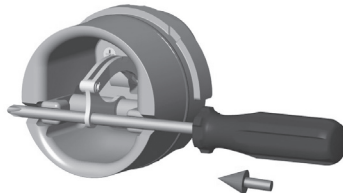

Figure E



Figure F

⚠ WARNING

Before servicing any Watts valve, shut down the water system by closing both the inlet and outlet shutoff valves. This is mandatory. After shutoff valves are closed, open test cocks No. 2, No. 3, and No. 4 to relieve pressure within the backflow assembly.

- After test cock No. 3 has been opened to relieve pressure, remove the test cock from the housing. (See Figure A.)
- Insert a #3 screwdriver through the hole on the top of the cover sleeve and, using both hands, rotate the cover sleeve approximately a quarter turn clockwise and a quarter turn counterclockwise to break the sleeve O-ring seals. Using the screwdriver, slowly slide the cover sleeve to the downstream side of the housing. (See Figure B.)
- Remove the stainless steel check retainer from the housing. (See Figure B.)
- Remove check module No. 1 by inserting two flat blade screwdrivers into the slots on either side of the check module. (See Figure C.) Gently pry the check module toward the open zone.
- Repeat step 4 to remove check module No. 2. (For servicing 6" checks, see the maintenance instructions for valve sizes 8" to 10".)
- To clean or inspect either check module, insert a #3 screwdriver through the downstream side of the check module. (See Figures D and E.) When the screwdriver is in place, remove the E-clip and the pin connecting the structural members. (See Figure F.) The check clapper opens with no tension.
- Clean the seating area thoroughly. The sealing disc can be removed, if necessary, by detaching the screws connecting the keeper plate to the clapper. The sealing disc can be reversed and reinstalled if the elastomer is cut or damaged.
- Wash check module and O-ring then inspect for any damage. If damaged, install new parts during reassembly.
- After a thorough cleaning, lubricate the O-ring with an FDA Approved lubricant, replace the pin and E-clip in the structural members, remove screwdriver, and reinstall the check modules. Reverse the order of these steps to reassemble the parts and housing.

Maintaining the Check Modules

8" – 10"

Material/Tool Requirements

- #3 Phillips screwdriver or $\frac{5}{16}$ " diameter rod, length sufficient to span diameter of check (See Figures A and B.)
- $\frac{1}{2}$ " 13 x 5 fully threaded hex bolt (Service bolt)
- $\frac{3}{4}$ " open end or socket wrench

Instructions

⚠ WARNING

Before servicing any Watts valve, shut down the water system by closing both the inlet and outlet shutoff valves. This is mandatory. After shutoff valves are closed, open test cocks No. 2, No. 3, and No. 4 to relieve pressure within the backflow assembly.

1. After test cock No. 3 has been opened to relieve pressure, remove the test cock from the housing.

When repairing a 6", 8", or 10" device, remove both Victaulic couplers from the body. Slide the downstream Victaulic coupler gasket to the downstream side of the housing. The upstream Victaulic coupler gasket stays in place.

2. Remove the check(s) to be serviced.
3. Locate the service hole and thread in the service bolt by hand until it contacts the linkage. (See Figure A.)
4. Continue to thread in the service bolt with the wrench until the service hole in the linkage is aligned with the service notches on the spring arbors. (See Figure A.)
5. Insert the Phillips screwdriver through the arbors and service hole of the linkage, making sure the tip of the screwdriver extends past the ends of the arbors by a minimum of $\frac{1}{4}$ ". (See Figure B.)
6. Loosen the service bolt until the load is transferred to the screwdriver. Continue to loosen the service bolt until sufficient clearance is achieved to remove the complete spring mechanism.
7. To disconnect the linkage, remove the retaining clip and pin. (Store both items in a safe location for reinstallation.)
8. To remove the spring mechanism, grasp the screwdriver at the center and pull the complete assembly straight out. Store in a safe place.
9. Reverse the order of these steps to reassemble the parts and housing.

⚠ WARNING

While the spring mechanism is removed for check servicing, never pull the screwdriver out or off the support notches on the arbors. Doing so may cause bodily injuries.

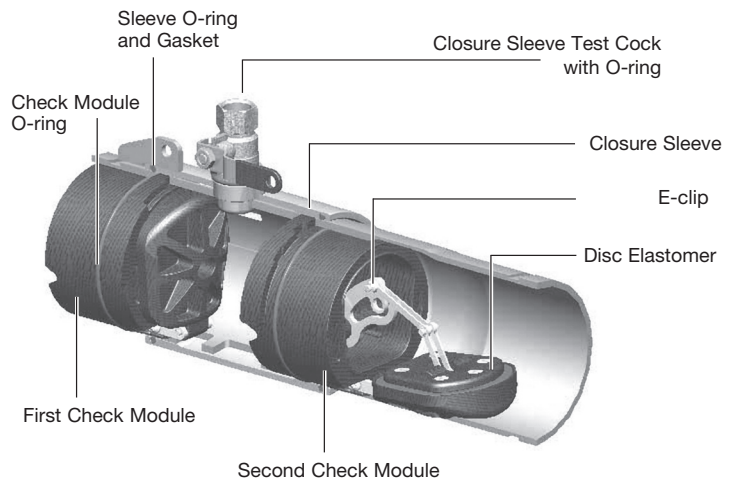
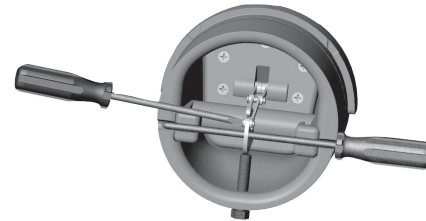
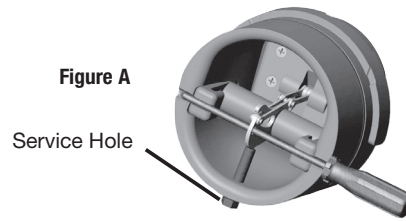

For repair kits and parts, refer to the Water Safety, Flow Control and Backflow Prevention Products PL-WATTS price list at watts.com.

Troubleshooting

PROBLEM	CAUSE	SOLUTION
Check valve fails to hold 1.0 PSID minimum	Debris on check disc sealing surface	Disassemble and clean
	Leaking gate valve	Disassemble and clean or repair
	Damaged seat disc or seat O-ring	Disassemble and replace
	Damaged guide holding check open	Disassemble and clean or replace
	Weak or broken spring	Disassemble and replace spring
Chatter during flow conditions	Worn, damaged or defective guide	Disassemble and repair or replace guide
Low flows passing through mainline valve	Mainline check fouled	Disassemble and clean
	Meter strainer plugged	
	Damaged mainline seat disc or seat	Disassemble and replace
	Broken mainline spring	

Limited Warranty: Watts (the "Company") warrants each product to be free from defects in material and workmanship under normal usage for a period of one year from the date of original shipment. In the event of such defects within the warranty period, the Company will, at its option, replace or recondition the product without charge.

THE WARRANTY SET FORTH HEREIN IS GIVEN EXPRESSLY AND IS THE ONLY WARRANTY GIVEN BY THE COMPANY WITH RESPECT TO THE PRODUCT. THE COMPANY MAKES NO OTHER WARRANTIES, EXPRESS OR IMPLIED. THE COMPANY HEREBY SPECIFICALLY DISCLAIMS ALL OTHER WARRANTIES, EXPRESS OR IMPLIED, INCLUDING BUT NOT LIMITED TO THE IMPLIED WARRANTIES OF MERCHANTABILITY AND FITNESS FOR A PARTICULAR PURPOSE.

The remedy described in the first paragraph of this warranty shall constitute the sole and exclusive remedy for breach of warranty, and the Company shall not be responsible for any incidental, special or consequential damages, including without limitation, lost profits or the cost of repairing or replacing other property which is damaged if this product does not work properly, other costs resulting from labor charges, delays, vandalism, negligence, fouling caused by foreign material, damage from adverse water conditions, chemical, or any other circumstances over which the Company has no control. This warranty shall be invalidated by any abuse, misuse, misapplication, improper installation or improper maintenance or alteration of the product.

Some States do not allow limitations on how long an implied warranty lasts, and some States do not allow the exclusion or limitation of incidental or consequential damages. Therefore the above limitations may not apply to you. This Limited Warranty gives you specific legal rights, and you may have other rights that vary from State to State. You should consult applicable state laws to determine your rights. **SO FAR AS IS CONSISTENT WITH APPLICABLE STATE LAW, ANY IMPLIED WARRANTIES THAT MAY NOT BE DISCLAIMED, INCLUDING THE IMPLIED WARRANTIES OF MERCHANTABILITY AND FITNESS FOR A PARTICULAR PURPOSE, ARE LIMITED IN DURATION TO ONE YEAR FROM THE DATE OF ORIGINAL SHIPMENT.**



USA: T: (978) 689-6066 • Watts.com

Canada: T: (888) 208-8927 • Watts.ca

Latin America: T: (52) 55-4122-0138 • Watts.com