

Series 009-SS

009-SS-202312

Reduced Pressure Zone Device

Size: DN20-DN50

Series 009-SS Reduced Pressure Zone devices are designed to protect potable water supplies in accordance with national plumbing codes and water authority requirements. This series can be used in a variety of installations, including the prevention of health hazard cross-connections in piping systems or for containment at the service line entrance.

This series features stainless steel construction, two in-line independent check valves, captured springs and replaceable check seats with an intermediate relief valve. Its compact modular design facilitates easy maintenance and assembly access.

Features

- Compact, space saving design
- Stainless Steel body construction for durability
- Large body passages provide low pressure drop
- Top entry single access cover and modular check construction
- No special tools required for maintenance
- Captured springs for safe maintenance
- Internal relief valve for reduced installation clearance
- Replaceable seats for economical repair
- Stainless steel ball valve test cocks – slotted
- Stainless steel ball valves, strainer and unions combine for a complete solution

Pressure - Temperature

- Temperature Range: 0.5°C – 90°C
- Maximum Working Pressure: 1600kPa (16bar)

Material

Component	Material
Body/Cover	Stainless Steel
Test Cock	Stainless Steel
Checks	Polymer
Check Seats (Replaceable)	Silicone Rubber Disk
Relief valve Seats (Replaceable)	Stainless Steel
Cover Bolts	Stainless Steel

Installation Dimensions

Dimensions (mm)	DN(mm)				
	20	25	32	40	50
L	460	560	650	705	815
L1	137	192	256	256	300
L2	68	78	84	97	103
L3	81	90	106	118	140
L4	50	60	60	74	74
L5	65	76	90	102	120
H	90	90	90	90	105
H1	52	65	72	80	90
H2	35	62	62	62	87
H3	60	76	84	95	100
A	52	43	68	68	75

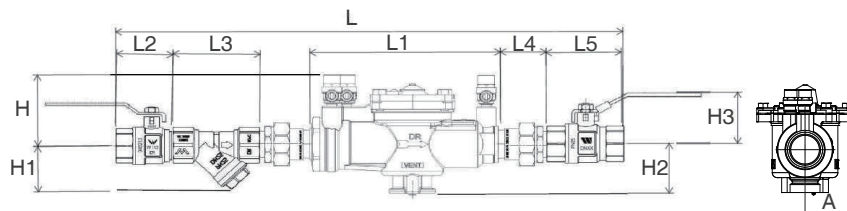

009-SS



009-SS-ULBS



009-SS- HYBRID



Specification

- Design Standard: AS/NZS 2845.1
- Connections: MxM BSP
- Working Medium: Non-Corrosive Liquids

Approval



- Lic. No. of Backflow Preventer: WMKA 25866
- Lic. No. of Ball Valves: WMK 26438
- Lic. No. of Y Strainer & Unions: WMK 22807

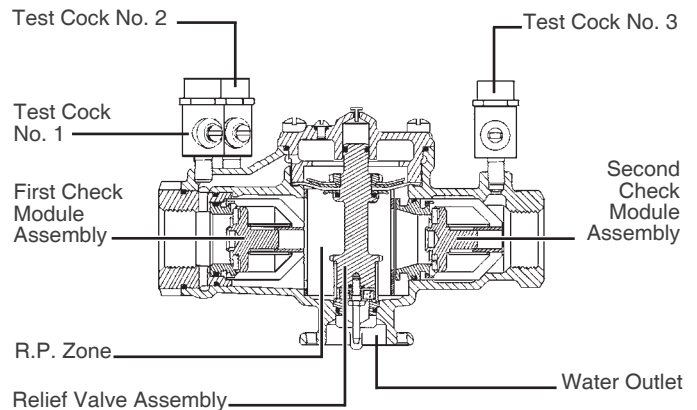

Models

Model NO.	Description
009-SS-020	20mm RPZD SS M&M - DEVICE ONLY
009-SS-025	25mm RPZD SS M&M - DEVICE ONLY
009-SS-032	32mm RPZD SS M&M - DEVICE ONLY
009-SS-040	40mm RPZD SS M&M - DEVICE ONLY
009-SS-050	50mm RPZD SS M&M - DEVICE ONLY
009-SS-020-ULBS	20mm RPZD SS – C/W LOCKABLE B/VALVES, STRAINER & UNIONS
009-SS-025-ULBS	25mm RPZD SS – C/W LOCKABLE B/VALVES, STRAINER & UNIONS
009-SS-032-ULBS	32mm RPZD SS – C/W LOCKABLE B/VALVES, STRAINER & UNIONS
009-SS-040-ULBS	40mm RPZD SS – C/W LOCKABLE B/VALVES, STRAINER & UNIONS
009-SS-050-ULBS	50mm RPZD SS – C/W LOCKABLE B/VALVES, STRAINER & UNIONS
009-SS-020-ULBS-BRS	20mm RPZD SS – C/W Brass LOCKABLE B/VALVES, STRAINER & UNIONS
009-SS-025-ULBS-BRS	25mm RPZD SS – C/W Brass LOCKABLE B/VALVES, STRAINER & UNIONS
009-SS-032-ULBS-BRS	32mm RPZD SS – C/W Brass LOCKABLE B/VALVES, STRAINER & UNIONS
009-SS-040-ULBS-BRS	40mm RPZD SS – C/W Brass LOCKABLE B/VALVES, STRAINER & UNIONS
009-SS-050-ULBS-BRS	50mm RPZD SS – C/W Brass LOCKABLE B/VALVES, STRAINER & UNIONS

Characteristic Curves

Performance as established by an independent testing laboratory.

***Typical maximum system flow rate (7.5 feet/sec., 2.3 meters/sec.)**

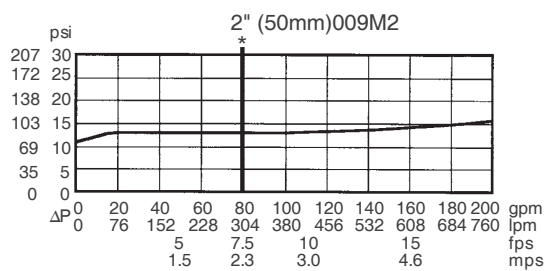
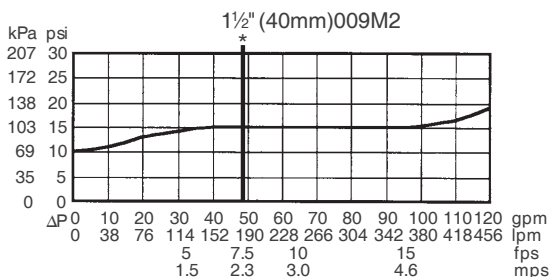
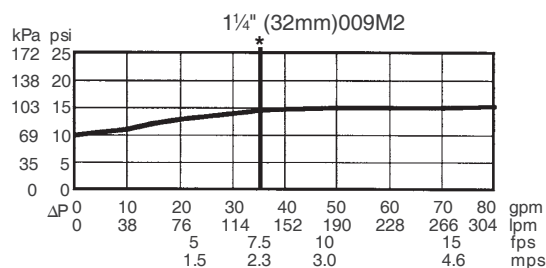
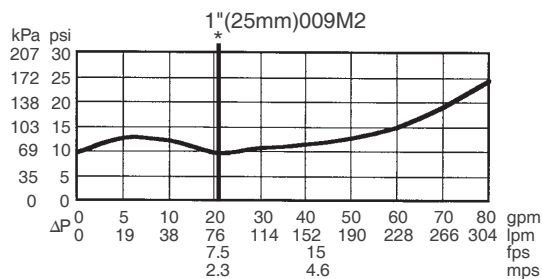
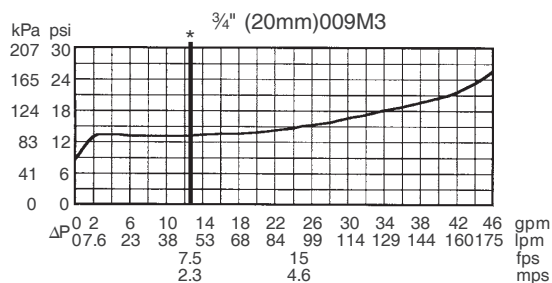

Note: US gpm

DISCLAIMER: Every care has been taken in the preparation of these instructions, which have been issued as a guide only. Compliance with the requirements of local Authorities is required at all times. These requirements may change from time to time. Always be aware of the local requirements. Subject to any statutory obligations and manufacturers warranties no liability can be accepted for any losses, consequential or otherwise which may arise or be said to have arisen from relying upon the contents of this installation instruction as to the fitness of any particular product for any particular purpose, use or application. The Australian Valve Group Pty Ltd reserves the right to modify designs and specifications and to withdraw and introduce products at any time without notice.

Typical Installation

Model 009-SS Reduced Pressure Zone Device should be installed with adequate clearance and easy accessibility for testing and maintenance and must be protected from freezing. Local codes shall govern installation requirements.

Fittings such as end connectors intended to join alternative pipe systems made from other materials (e.g. plastics) shall also conform to the relevant dimensional and performance requirements of the appropriate Australian, New Zealand, or joint Australian/New Zealand Standard for the alternative pipe system.

Test the assembly at initial installation, after servicing or maintenance to AS/NZS2845.3 and local regulatory authority requirements.

DISCLAIMER: Every care has been taken in the preparation of these instructions, which have been issued as a guide only. Compliance with the requirements of local Authorities is required at all times. These requirements may change from time to time. Always be aware of the local requirements. Subject to any statutory obligations and manufacturers warranties no liability can be accepted for any losses, consequential or otherwise which may arise or be said to have arisen from relying upon the contents of this installation instruction as to the fitness of any particular product for any particular purpose, use or application. The Australian Valve Group Pty Ltd reserves the right to modify designs and specifications and to withdraw and introduce products at any time without notice.