



# INSTALLATION INSTRUCTIONS FOR PRESSURE REDUCING VALVES (PRV and NRI-PRV) 15mm, 20mm & 25mm



## FUNCTION

Pressure reducing valves are installed to reduce & stabilize inlet pressure of mains water supply and to allow domestic water heaters and appliances to operate properly.

## PRODUCT RANGE

Pressure reducing valve sizes:  
15mm (1/2"), 20mm (3/4") &  
25mm (1")

## MODELS:

PRV15F, PRV20F and PRV25F  
Female BSP connections

## MODELS:

NRI-PRV-15C &  
NRI-PRV-20C  
CxC connections.

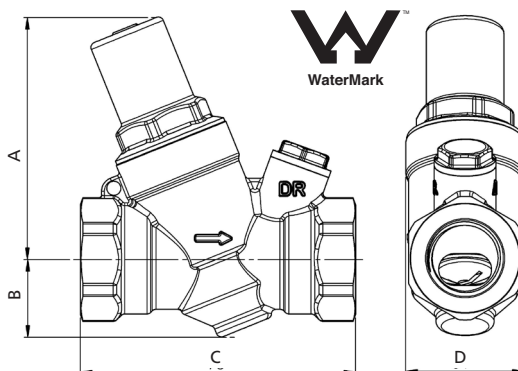

MODEL NO.	A	B	C	D
PRV15F	68mm	22mm	78mm	34mm
PRV20F	68mm	22mm	78mm	34mm
PRV25F	70mm	25mm	83mm	38mm

## PRV TECHNICAL SPECIFICATIONS

### Materials:

Body:	DR Brass
Control Spindle:	DR Brass
Seat:	Stainless Steel 316
Seals:	EPDM Rubber
Strainer:	Stainless Steel
Spring:	Stainless Steel

### Performance:

Pressure setting range:	250-750 kPa
Factory Setting:	500 kPa
Max inlet Pressure:	1600 kPa
Max working Temp.:	80 °C
Medium:	Water
Complies with	AS1357.2
Flow rate as per Appendix M @ 700 kPa dynamic	
PRV15 set pressure 500 kPa	Flow rate 60 L/Min
set pressure 250 kPa	Flow rate 22 L/Min
PRV20 set pressure 500 kPa	Flow rate 130 L/Min
set pressure 250 kPa	Flow rate 30 L/Min
PRV25 set pressure 500 kPa	Flow rate 155 L/Min
set pressure 260 kPa	Flow rate 25.4 L/Min
set pressure 750 kPa	Flow rate 165 L/Min



Leave this operating manual with the user

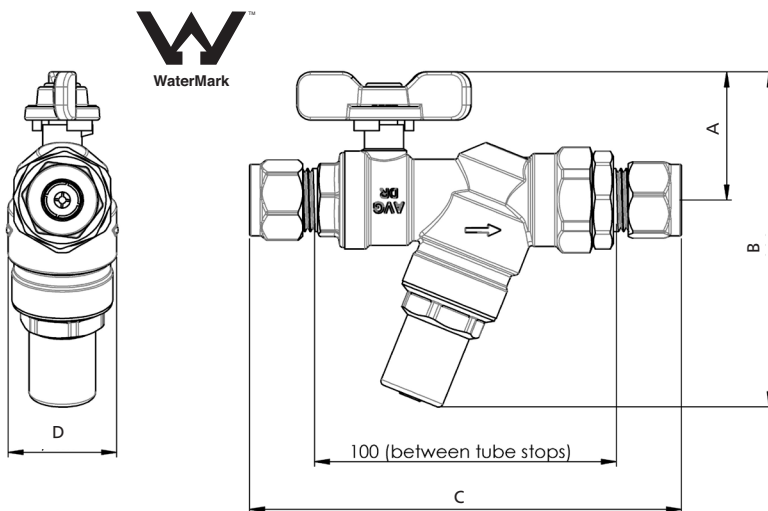

MODEL NO.	A	B	C	D
NRI-PRV-15C	43mm	111mm	143mm	36mm
NRI-PRV-20C	43mm	111mm	146mm	36mm

## NRI-PRV TECHNICAL SPECIFICATIONS

### Materials:

Body:	DR Brass
Control Spindle:	DR Brass
Seat:	Stainless Steel 316
Seals:	EPDM Rubber
Strainer:	Stainless Steel
Spring:	Stainless Steel

### Performance:

Pressure setting range:	250-650 kPa
Factory Setting:	500 kPa
Max inlet Pressure:	1600 kPa
Max working Temp.:	80 °C
Medium:	Water
Complies with	AS1357.2
Flow rate as per Appendix K @ 700 kPa dynamic	
NRI-PRV-15C	
set pressure 500 kPa	Flow rate 55 L/Min
set pressure 250 kPa	Flow rate 22 L/Min
NRI-PRV-20C	
set pressure 500 kPa	Flow rate 120 L/Min
set pressure 250 kPa	Flow rate 30 L/Min

## IMPORTANT NOTE:

Flush out your lines to remove any debris or dirt particles that may cause the valve to malfunction.

## Installation

The pressure reducing valve must be installed by a licensed plumber and in accordance with AS/NZS 3500, the Building Code, all relevant local requirements and the following manufacturer's instructions.

1. The pressure reducing valve may be installed horizontally or vertically.
2. It is recommended that isolation valves be fitted either side of the Pressure reducing valve to assist future maintenance operations.
3. The PRV15, PRV20 and PRV25 are protected by an internal stainless steel mesh filter. If the valve is being installed in an environment where fine dirt particles are present it is recommended that a line strainer be fitted upstream of the valve.
4. Ensure that the valve is installed in an accessible position for future maintenance operations.
5. Install the valve with the arrow on the valve body pointing in the direction of flow.

For best operation the inlet pressure should be at least 150 kPa higher than the outlet pressure.

## Recommendations for installation

1. Do not install PRV's below ground unless the valve is fitted inside a protective box as to prevent damage and corrosion by chemicals in the soil.
2. If the installation is at risk of water hammer, fit a water hammer arrestor. If the pressure setting is important for the protection of equipment fit a pressure relief valve downstream of the valve.
3. Multistorey Buildings - where multiple pressure reducing valves will be used as part of a hydraulic circuit, consideration should be given to the design of the hydraulic circuit to avoid the operating condition where combined high inlet pressure/low outlet flow-rate results in high water velocity within the Pressure Reducing Valve. Where inlet pressures are likely to exceed 1,000 kPa, this may be achieved through staged pressure reduction measures.

## Installation Diagram

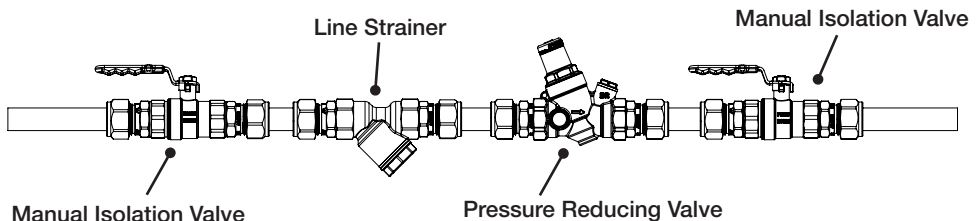

Leave this operating manual with the user

## Pressure Adjustment

The Pressure reducing valve has been factory set to **500kPa** and has an adjustment range of 250 - 750kPa.

### To adjust the pressure:

1. Ensure the lines have been flushed and the air purged from the system.
2. Turn the water off and relieve the pressure from the system.
3. Remove the test point plug located on the outlet side of the valve and fit your test gauge.
4. Turn the water on and observe the gauge pressure.
5. Using a screw driver turn the screw clockwise to increase the pressure and anti-clockwise to decrease the pressure.
6. During this process it may be necessary to open a tap on the line and allow water to run and then close the tap to confirm your adjustment. Check your test gauge and repeat if necessary.
7. Repeat steps 2 and 3 and remove test gauge and re-fit test point plug.
8. Make sure all joints are water tight and check for leaks.

Adjustment Diagram

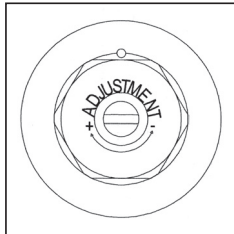

### CAUTION!

If the pressure reducing valve is not installed, commissioned and maintained properly in accordance with the instructions contained in this manual, it may not operate correctly, and cause damage to objects and or persons.

**Disclaimer:** Every care has been taken in the preparation of these instructions, which have been issued as a guide only. Compliance with the requirements of local Authorities is required at all times. These requirements may change from time to time. Always be aware of local requirements. Subject to any statutory obligations and manufacturers warranties no liability can be accepted for any losses, consequential or otherwise which may arise or be said to have arisen from relying upon the contents of this installation instruction as to the fitness of any particular product for any particular purpose, use or application. The Australian Valve Group Pty Ltd reserves the right to modify designs and specifications and to withdraw and introduce products at any time without notice.