

Series WA-M115

ACV: Pressure Reducing Valve

Size: DN65 - DN200

The Watts WA-M115 Watermarked Pressure Reducing Valve is designed to automatically reduce a fluctuating or high inlet pressure to a stable lower outlet pressure. The outlet pressure is adjustable over a broad range and remains stable from maximum to minimum rated flows.

Features

- Certified to Australian Standard 5081 for control valves
- Certified to AS4020 for drinking water
- Stainless steel trim as standard, for greater reliability & service life
- Dual pressure gauges as standard, for ease of setting and confidence in performance
- Factory tested and downstream pressure preset to 500 kPa as standard

Pressure-Temperature

- Operating Pressure: up to 1600kPa Standard, higher pressures on request
- Temperature Range: 0-40°C
- Set Pressure Range: Standard: 70 to 860 kPa (set at 500 kPa)

Test Pressures

- Body Test Pressure: 2400 kPa
- Seat Test Pressure: 1760 kPa
- Based on Table E Flange

Material

Component	Material
Body/bonnet	Ductile Iron with Epoxy Resin, NSF Certified Coating
Stem/seat	Stainless Steel
Diaphragm	Nylon Reinforced NBR
Main valve seal	NBR
Pressure reducing pilot	Stainless Steel
Pilot strainer, needle valve & fittings	Brass or Bronze
Pilot tubing	Copper

Operating Principle

The main valve is controlled by the action of the pressure reducing pilot valve. If the downstream pressure is below the set pressure then the pilot valve opens, releasing water from the top chamber of the main valve, causing the main valve to open and downstream pressure to rise. As the downstream pressure nears the set point the pilot valve begins to close a little, resulting in more water accumulating in the top chamber of main valve, causing main valve to modulate and maintain the downstream pressure. If the downstream pressure increases above the set point, the pilot valve closes completely, resulting in full line pressure gently closing the main valve and creating a drip tight seal. In this way the main valve responds precisely to accurately maintain the downstream pressure.



Specification

- Connection Type: Flanged to AS 2129 Table E
- Working Medium: Non corrosive liquids

Approvals

- Water Mark License No.: WMK26355
- Standards Mark License No.: SMK26355

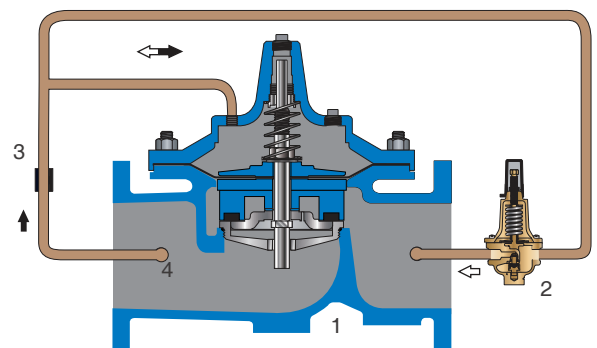

FLOW ↻
 — CLOSING VALVE
 — OPENING VALVE
 1 - Main Valve
 2 - Pressure Reducing Control
 3 - Fixed Orifice
 4 - Flo-Clean Strainer

Installation Dimensions

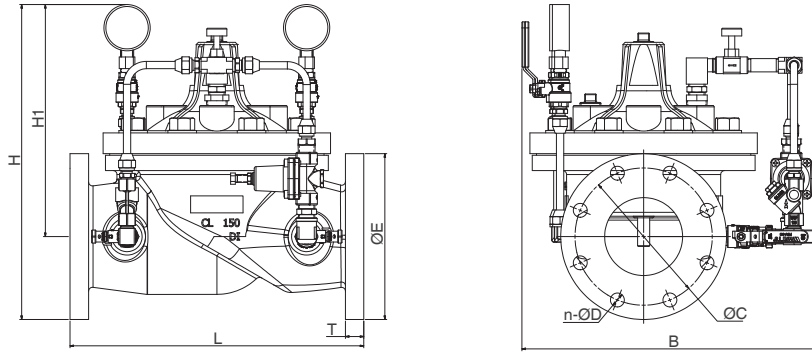

Size DN		Dimensions(mm)				Flange Dimensions(mm)				Weight (Kg)
		L	H	H1	B	ØC	n-ØD	ØE	T	
65	Flanged	280	355	272	305	127	4-18	165	22.4	22
80	Flanged	305	380	276	365	146	4-18	185	23.9	36.4
100	Flanged	381	413	305	370	178	8-18	215	23.9	52.1
150	Flanged	508	515	375	420	235	8-22	280	25.4	111.8
200	Flanged	645	575	402	510	292	8-22	335	28.4	197

Flow Rates

Size DN	50	65	80	100	150	200
Maximum Continuous (l/s)	13	19	31	50	117	196
Maximum Intermittent (l/s)	17	25	37	63	145	252
Minimum Continuous (l/s)	0.4	0.6	0.9	1.0	1.1	1.6

Installation General Instructions

- Prior to installation, flush line to remove debris.
- Install valve horizontally "in line" (cover facing UP), so flow arrow matches flow through the line. Avoid installing valves 150mm and larger vertically, flow must be upwards. Consult factory prior to ordering if installation is other than described.
- Install inlet and outlet isolation valves. NOTE: When using butterfly valves, insure disc does not contact control valve, as damage or improper valve seating may occur.
- Provide adequate clearance for valve servicing and maintenance.
- If installation is subjected to very low flow or potentially static conditions, it is recommended a pressure relief valve (15mm minimum) be installed downstream of the Pressure Reducing Valve for additional system protection.

General Application

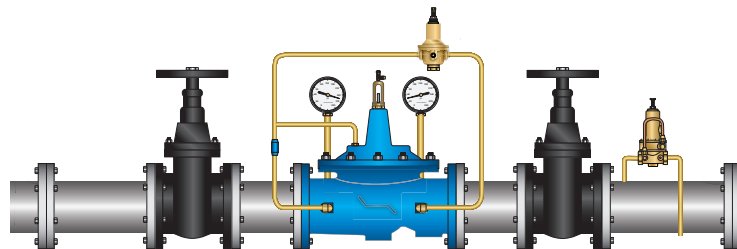

Models

Model NO.	Description
ACV-065-TEWM-WATTS	65MM ACV M115 MUSTANG TABLE E FULL PORT WATERMARKED -WATTS
ACV-080-TEWM-WATTS	80MM ACV M115 MUSTANG TABLE E FULL PORT WATERMARKED -WATTS
ACV-100-TEWM-WATTS	100MM ACV M115 MUSTANG TABLE E FULL PORT WATERMARKED -WATTS
ACV-150-TEWM-WATTS	150MM ACV M115 MUSTANG TABLE E FULL PORT WATERMARKED -WATTS
ACV-200-TEWM-WATTS	200MM ACV M115 MUSTANG TABLE E FULL PORT WATERMARKED -WATTS