

Series 009

009-EN-202405

Reduced Pressure Zone Device

Size: DN15-DN50

Series 009 Reduced Pressure Zone Devices are designed to protect potable water supplies in accordance with national plumbing codes and water authority requirements. This series can be used in a variety of installations, including the prevention of health hazard cross-connections in piping systems or for containment at the service line entrance.

This series features two in-line, independent check valves, captured springs and replaceable check seats with an intermediate relief valve. Its compact modular design facilitates easy maintenance and assembly access.

Features

- Compact, space saving design
- Bronze body construction for durability
- Large body passages provides low pressure drop
- Top entry single access cover and modular check construction for ease of maintenance
- No special tools required for servicing
- Captured springs for safe maintenance
- Internal relief valve for reduced installation clearances
- Replaceable seats for economical repair
- Ball valve test cocks — screwdriver slotted

Pressure - Temperature

- Temperature Range: 0.5°C – 90°C
- Maximum Working Pressure: 1400kPa (14bar)

Material

Component	Material
Body/Cover	DR Bronze
Test Cock	DR Brass
Checks	Polymer
Check Seats (Replaceable)	Silicone Rubber Disc
Relief Valve Seats (Replaceable)	Stainless Steel
Cover Bolts	Stainless Steel

Installation Dimensions

Dimensions (mm)	DN(mm)					
	15	20	25	32	40	50
L	335	378	472	604	636	739
L1	137	168	235	287	283	340
L2	41	49	58	70	81	94
L3	63	72	86	101	111	134
L4	35	39	43	49	52	55
L5	56	66	77	92	103	120
H	85	91	80	92	92	108
H1	43	49	54	79	79	90
H2	30	35	60	62	62	87
H3	42	49	52	77	83	90
A	52	39	43	68	68	68

009 KIT

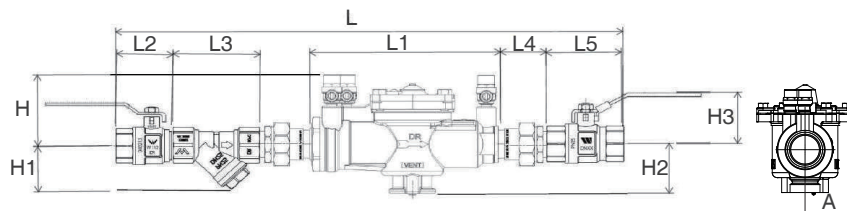

009

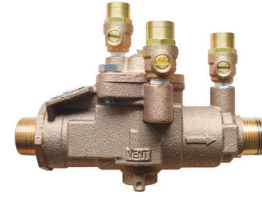

009-LBS

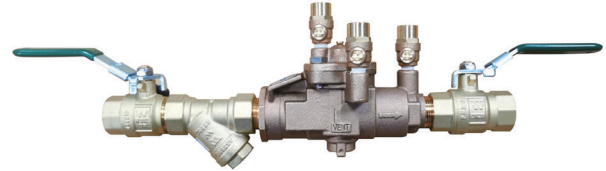

009-ULBS

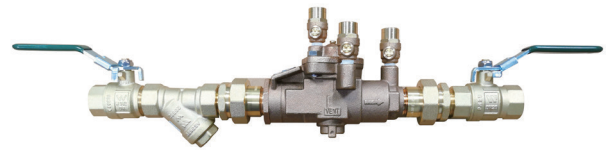

Specification

- Design Standard: AS/NZS 2845.1
- Connection Standard: DN15: MxF BSP
DN20-DN50: MxM BSP
- Working Medium: Non corrosive liquids

Approval



- License No. of the Backflow Preventer: WMKA 1335
- License No. of Ball Valves: WM 040213
- License No. of the Y-Strainer & Unions: WMK 25882

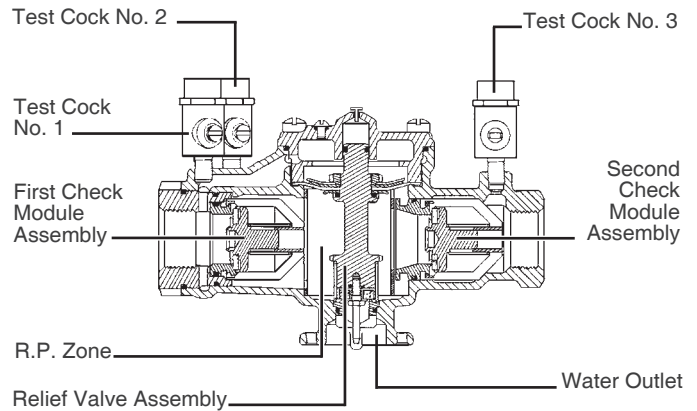

Models

Model NO.	Description
009-015	15MM RPZD BRASS DEVICE ONLY M&F - DEVICE ONLY
009-020	20MM RPZD BRASS DEVICE ONLY M&M - DEVICE ONLY
009-025	25MM RPZD BRASS DEVICE ONLY M&M - DEVICE ONLY
009-032	32MM RPZD BRASS DEVICE ONLY M&M - DEVICE ONLY
009-040	40MM RPZD BRASS DEVICE ONLY M&M - DEVICE ONLY
009-050	50MM RPZD BRASS DEVICE ONLY M&M - DEVICE ONLY
009-015-LBS	15MM RPZD BRASS C/W LOCKABLE B/VALVES & STRAINER
009-020-LBS	20MM RPZD BRASS C/W LOCKABLE B/VALVES & STRAINER
009-025-LBS	25MM RPZD BRASS C/W LOCKABLE B/VALVES & STRAINER
009-032-LBS	32MM RPZD BRASS C/W LOCKABLE B/VALVES & STRAINER
009-040-LBS	40MM RPZD BRASS C/W LOCKABLE B/VALVES & STRAINER
009-050-LBS	50MM RPZD BRASS C/W LOCKABLE B/VALVES & STRAINER
009-015-ULBS	15MM RPZD BRASS C/W LOCKABLE B/VALVES, STRAINER & UNIONS
009-020-ULBS	20MM RPZD BRASS C/W LOCKABLE B/VALVES, STRAINER & UNIONS
009-025-ULBS	25MM RPZD BRASS C/W LOCKABLE B/VALVES, STRAINER & UNIONS
009-032-ULBS	32MM RPZD BRASS C/W LOCKABLE B/VALVES, STRAINER & UNIONS
009-040-ULBS	40MM RPZD BRASS C/W LOCKABLE B/VALVES, STRAINER & UNIONS
009-050-ULBS	50MM RPZD BRASS C/W LOCKABLE B/VALVES, STRAINER & UNIONS

Characteristic Curves

Performance as established by an independent testing laboratory.

*Typical maximum system flow rate (7.5 feet/sec., 2.3 meters/sec.)

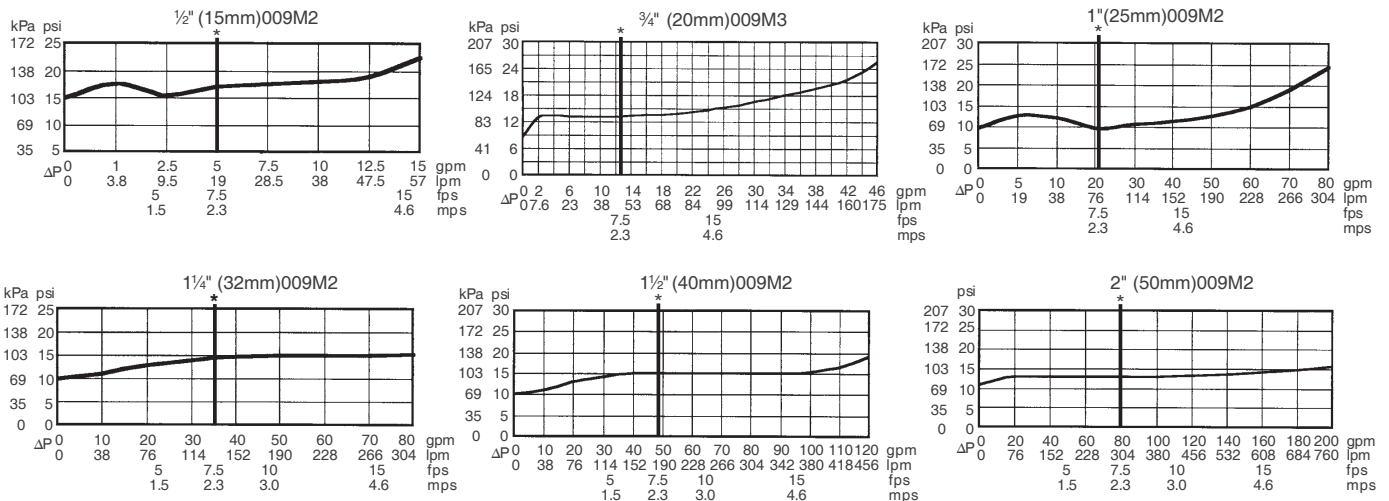

Note: US gpm

DISCLAIMER: Every care has been taken in the preparation of these instructions, which have been issued as a guide only. Compliance with the requirements of local Authorities is required at all times. These requirements may change from time to time. Always be aware of the local requirements. Subject to any statutory obligations

and manufacturers warranties no liability can be accepted for any losses, consequential or otherwise which may arise or be said to have arisen from relying upon the contents of this installation instruction as to the fitness of any particular product for any particular purpose, use or application. The Australian Valve Group Pty Ltd reserves the right to modify designs and specifications and to withdraw and introduce products at any time without notice.

Typical Installation

Model 009 Reduced Pressure Zone Device should be installed with adequate clearance and easy accessibility for testing and maintenance and must be protected from freezing. Local codes shall govern installation requirements.

Fittings such as end connectors intended to join alternative pipe systems made from other materials (e.g. plastics) shall also conform to the relevant dimensional and performance requirements of the appropriate Australian, New Zealand, or joint Australian/New Zealand Standard for the alternative pipe system.

Test the assembly at initial installation, after servicing or maintenance to AS/NZS2845.3 and local regulatory authority requirements.