

Solar Control Kits, QIK15SCK-1 & QIK15SCK-2

The new AVG Solar Control Valve is a cold water inlet combination valve for a roof mounted solar hot water heater. The valve assembly is installed in a convenient position for ease of operation.

This innovative cold water inlet combination incorporates an NRI/PRV, strainer and ECV all in one neat package designed with the installing plumber in mind.

The Solar Control Valve requires no thread sealant or tape to assemble and has 15mm compression inlet and outlet connections.

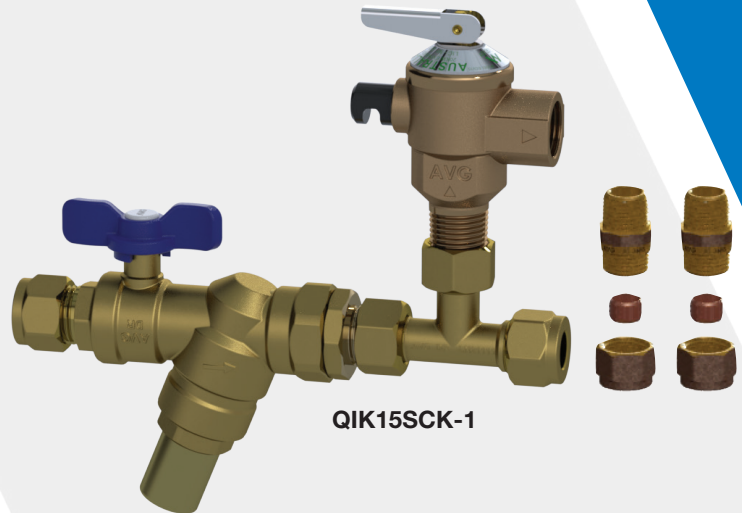

QIK15SCK-1

DIMENSIONS

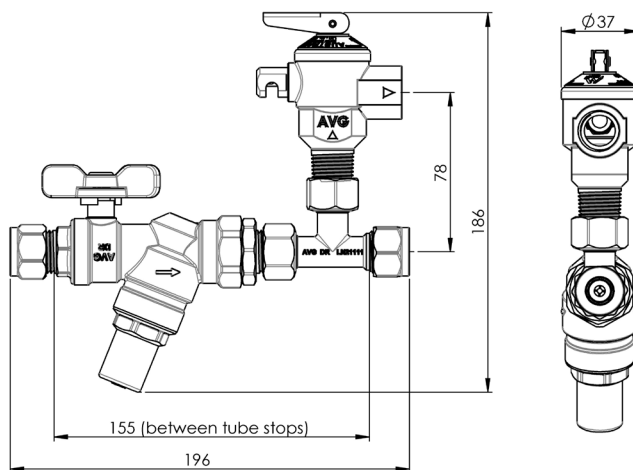

Features

- Compact design
- Convenient isolation for service or repairs
- Adjustable pressure
- All directional ECV position
- Replaceable ECV
- Vertical or horizontal orientation
- **High Performance TVA included in QIK15SCK-2 kits**

Specifications

Valve	DR brass
Line strainer	Stainless steel
Check valve cartridge.	NORYL
O rings	EPDM
End connections	15mm
Compression olives	Copper

DISCLAIMER: Every care has been taken in the preparation of these instructions, which have been issued as a guide only. Compliance with the requirements of local Authorities is required at all times. These requirements may change from time to time. Always be aware of the local requirements. Subject to any statutory obligations and manufacturers warranties no liability can be accepted for any losses, consequential or otherwise which may arise or be said to have arisen from relying upon the contents of this installation instruction as to the fitness of any particular product for any particular purpose, use or application. The Australian Valve Group Pty Ltd reserves the right to modify designs and specifications and to withdraw and introduce products at any time without notice.